



METEOR 30

PRODUCT MATERIAL	Aluminium and poly-carbonate
LIGHT SOURCE	SMD LED
MODULE LIFETIME	Approx. 40.000 hours
LED COOLING	Passive cooling
DRIVER	Incl. LED driver.
COLORS (Δ)	○ 3 = RAL 9003 white
BEAM ANGLE	▲ 120° Wide beam
REFLECTOR PLATE	Opal poly-carbonate diffuser
ADJUSTABLE	No
SIZE	300 X 48MM



OPTIONS

Options available on request.

- 25w version
- Sensor with dimmin to 10% brightness when no action

Ask our sales department for more information

INFORMATION

WARRANTY	3 Years
-----------------	---------

IP 54: For indoor use only

Microwave Sensor

Detection area:

- 140 degree wide detective beam angle with 5-7 meters distance.

Working pattern:

- In any given lighting condition, the light switches on automatically when presence detected.
- After presence left, light will continuously work within timedelay (30 seconds), then switch off automatically.
- After presence left, any movement detected within time-delay (30 seconds), the light will continuously work for another hold time (30 seconds), then switch off until next movement detected.
- Hold time: 30S

Keylight International reserves the right to modify or change technical, construction or LED specifications due to continuous improvements of our products and lightsources. The light source in this product can be replaced with an equivalent module made by Philips, Osram or Tridonic.

METEOR 30

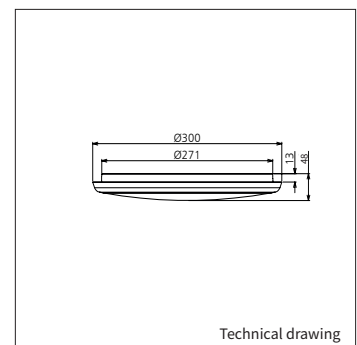

ART.NR.	LAMP TYPE	BRAND	LUMINOUS FLUX	OUTPUT POWER	MODULE EFFICIENCY	COLOUR TEMPERATURE	CRI	TC LIFETIME	POWER FACTOR
5142.300.18.3	SMD LED	Epistar	1620LM	18W	90LM/W	3000K	>80	40.000 Hrs	>0,9
5143.300.18.3 (sensor)	SMD LED	Epistar	1620LM	18W	90LM/W	3000K	>80	40.000 Hrs	>0,9